



Solar Water Heating and Plumbers

Presentation to Waikato Master Plumbers Association

Brian Cox, Executive Officer

29 August 2002

Government Policy

The solar water heating industry is fully supported by Government with two very significant policies. The principal parts of these policies that cover solar water heating are;

- National Energy Efficiency and Conservation Strategy
 - Significantly improve the energy efficiency of residential water heating systems
 - Accelerate development of the solar water heating industry
 - Development of a Home Energy Rating Scheme (HERS)
- Draft Renewable Energy programme
 - Partnership with Solar Industries Association
 - Solar Water Heating Action Plan
 - Target - 10, 000 new systems per year
 - Market transformation
 - Quality standards - training, skills, accreditation
 - Government purchase programme
 - Interim bid-in support fund
 - Effective public information

Solar Industries Association

The Solar Industries Association is an industry grouping of solar water heating manufacturers and suppliers.

The Association has a three year Action Plan which is initially focused on the establishment of good quality systems throughout the industry.

Principal recent areas of activity have been;

- Code of Conduct and Responsibility
- Accreditation for manufacture or supply
- Certification for installation
- Establishment of manufacture and performance standards

The Association undertakes collective promotion of solar water heating and is currently working to provide information to building professionals and potential purchasers that demonstrates that solar water heating can provide significant financial savings to hot water users.

The Association has established its work programme in partnership with Government through close working with EECA. A target has been established of achieving installation of 10,000 new systems per year by 2005. This represents an 8-10 fold increase over the number of current installations.

Design

Solar water systems are no longer alternative. Modern systems are very well suited for high value architecturally designed residential homes as well as commercial situations.

- Systems can be installed on new or existing buildings
- The economics are improved if the system is designed into the building from the beginning. At this stage orientation and positioning can be optimised and unnecessary electric or gas hot water systems can be avoided thus reducing capital cost.
- The design of the system can take particular attention to the aesthetics
 - Blended profile
 - Location
- Generally the best performing and cheapest system is a simple system

There are four principal flat plate solar system designs available in NZ.

Thermosyphon System

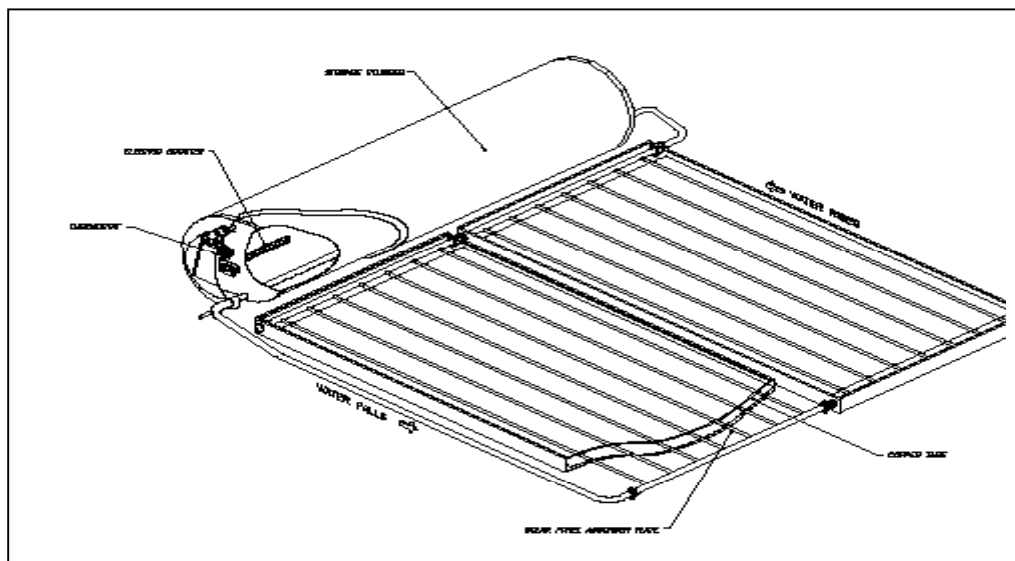

Thermosyphon systems can be either direct or indirect heating of the hot water. In the direct contact systems the cold water flows through the system panels and is heated directly. The heated water flows upwards to a storage tank. In the indirect systems the panels are filled with a glycol type thermal fluid which is heated by the solar radiation and then flows to a heat exchanger where the cold water is heated. The heat exchanger may be either at the top of the panel or within the storage cylinder.

Pumped system

A pumped system is usually when the solar panel and the storage cylinder are some distance apart. In fact the cylinder can be anywhere in or outside the building. A pumped system may be open looped where the water is pumped to the solar panels or an indirect closed loop where the glycol type thermal fluid is pumped from the panels to a heat exchanger with the storage cylinder.

Direct open looped system

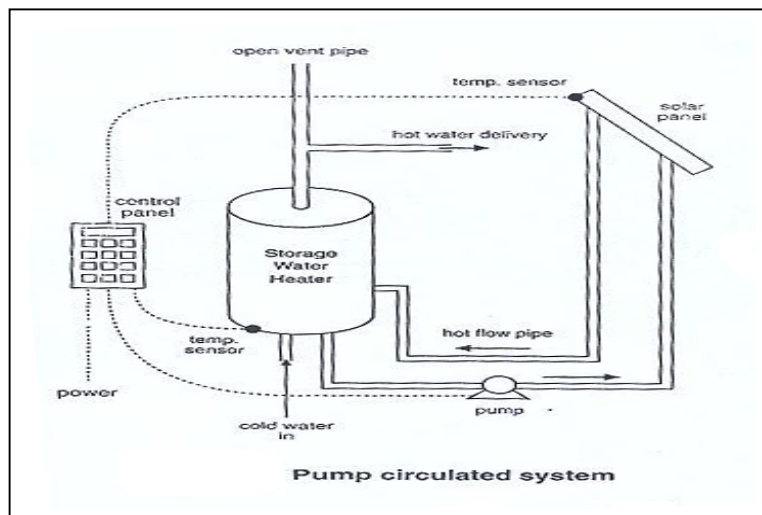

Indirect closed loop system

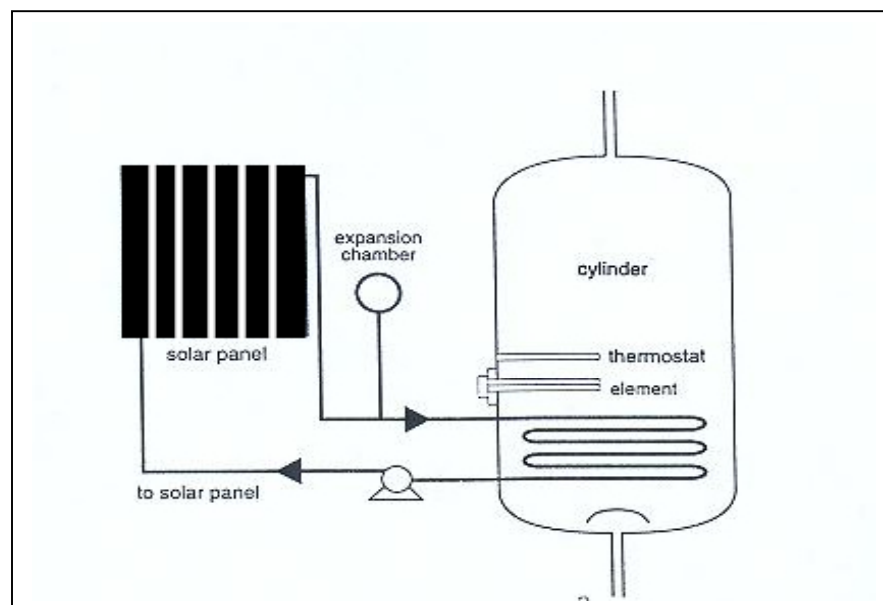

Economics

The financial benefits of installation of solar water heating are increasing. The increasing cost of electricity and gas make reductions in these forms of energy for heating water, and increased use of solar energy, very attractive for residential and commercial purchasers.

The economics depends on

- Regional location
- Building orientation to sun
- Lifestyle
- Family size (Number of teenage daughters)

Installing time switched controllers on electric boosters significantly improve economics by reducing unnecessary water heating. The solar system owner has their own ripple control.

Recent studies by BRANZ showed that;

- 42% of residential electricity costs arise from heating water
- 50-70% of hot water costs can be saved by installing a solar system

For a residential owner of a solar hot water system the financial payback can be 5-8 years according to energy use, location and size of system.

For commercial facility owners such as motels, hotels, institutions (prisons, hospitals) council swimming pools etc the financial payback can be as low as 3-5 years in high hot water use situations.

Solar Contribution Factor

Solar water heating systems are generally sized to meet approximately 70% of anticipated hot water demand. An electric or gas booster is generally installed to heat the water when solar energy is not available.

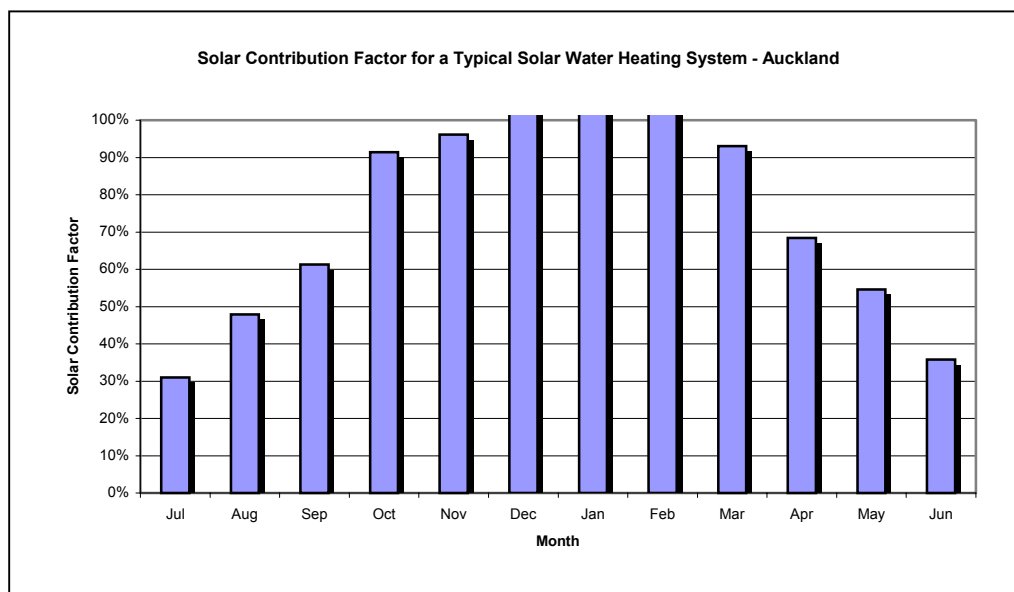

A time switch on the booster controller can limit the use of booster energy to when it is really needed, with significant cost savings.

Installation

The shortage of skilled installers is a major issue for the industry to address. Currently the Association is working with plumber organisations and the polytechnics to heighten the knowledge base and experience amongst the plumbing trade. With the support from Government for solar water heating this is providing a significant business opportunity for plumbers.

Generally purchasers of solar water systems experience few problems with the product, any problems generally relate to installation. The Association is therefore focusing its attention on this area. The Association is working with the Plumbers Training Organisation to upskill plumbers knowledge of solar water heating systems

- Apprenticeship
- Up-skilling registered plumbers

There is generally a need to develop working relationships between suppliers and installers. Some suppliers use only in-house installers to ensure quality, while others draw on strengths of local plumbers. Anyone interested in pursuing the business opportunity that solar water heating provides should make contact with members of the Association.

Further Information

For further information on solar water heating and the business opportunities that it provides plumbers contact the

Solar Industries Association
www.solarindustries.org.nz
P O Box 11595 Wellington
Tel. 04 385 3398